



KS100 Trench shoring Safe operating procedures

www.shorenz.co.nz



Contents

Introduction	1
Occupational safety and general remarks	2
Limitations and guidelines	3
System components	4
Checklist	5
Equipment	5
Unloading	7
Assembly	9
Extension units and spindle extensions	10
Operation	11
Disassembly	14
Loading	16
Standards	17
Notes	18



Introduction

Trench shoring systems provide a means for you to undertake pipeline and services installation work safely and efficiently. Following the guidelines outlined in this publication will help you to achieve this.

The Krings KS100 shoring system is designed and manufactured for safe use within the parameters of these procedures. These Safe Operating Procedures cover the loading, unloading, assembly and operation of the Krings KS100 shoring system and the Krings ECK500 Manhole Box.

These Safe Operating Procedures have been reviewed by the Department of Labour. They have advised their construction inspectors that this trench shoring is very good and should be used where possible.

Occupational safety and general remarks

Lifting, handling, pulling, dragging

Handling should be carried out as close to the ground as possible

Lifting chains must be chosen to suit the weight being handled.

To prevent the accidental detachment of the load use only load hooks with safety catches.

The load must be slung in such a way that the shoring is kept in a horizontal position and swinging during handling is reduced to a minimum.

The shoring must be lowered onto level and firm ground.

Do not stand within the pivoting range of the excavator or crane or beneath suspended loads.

A load operator must stand to the front of the excavator and be in eye contact with the machine operator.

Measures to reduce hazards

The safety of persons on site must be enhanced with the aid of signs, cones, warning tapes and/or safety staff specially deployed on site for this purpose.

The risk of instability as a consequence of wind loads when setting up or using shoring must be considered.

The shoring must be secured against accidental impacts and set up in an area of sufficient size and on firm ground.

Care must be taken to look out for and avoid contact with overhead cables when handling, installing and removing shoring.

Where the ground is sloping or uneven, the shoring should be set up, if possible, at right angles to the slope.

Reasons for taking parts out of service

Before use, all shoring components must be checked for their correct function. Reasons for taking parts out of service include:

- Missing parts, such as nuts, pins and safety clips
- Broken parts such as spindles, pins and spindle extensions.
- Severely worn or deformed parts or panels with holes.

Faulty parts must be replaced or repaired. Only original replacement parts from the manufacturer or TSNZ may be used.

In all cases of doubt always consult TSNZ or your distributor.

Limitations and guidelines

The KS100 shoring system is certified to operate at maximum loads for different configurations. If the operator is unsure of the loads likely to be encountered at a specific site, professional engineering advice should be sought to determine this.

Typical site conditions which affect lateral earth pressures (loads) are:

- Depth of excavation
- Soil types
- Ground water levels
- Surcharges – for example;
 - one or either side of a trench may have ground adjacent which slopes down to the trench.
 - buildings or other structures close to the trench
 - traffic close to the trench
- Differential surcharges – where the extra loading is on one side of the trench only.

Other elements which affect load capacity:

- The width at which the shoring is being used.
- Spindle angles – although spindle assemblies are designed so that while being installed or withdrawn shoring panels can be moved independently of each other, care should be taken to ensure that spindle assemblies remain at, or near, horizontal when shoring is in its working position. This ensures that the rated load capacities can be achieved and will avoid damage to spindle components. Spindle angles must be limited to no more than 8 degrees from the horizontal.

If spindle assemblies are not horizontal when loaded, bowing may occur in the assembly, which weakens load capacity and could bend or even break spindles.

Maximum load capacity table

	Maximum load (kN/m ²)
4.0m x 2.2m base assemblies	32
2.5m x 2.2m base assemblies	65
4.0m x 1.3m extension assemblies	33
2.5m x 1.3m extension assemblies	61

Shoring width guidelines:

- Shoring width is determined by either the outside diameter (OD) of the pipe or the OD of the excavator bucket being used.
- Allow 100mm to 150mm clearance each side of the pipe bell
- Inside shoring width should be a minimum of 100mm to 150mm wider than the excavator bucket.

All personnel using the Krings KS100 shoring system must be trained in the use and limitations of the equipment. If in any doubt, contact your distributor or Trench Shoring New Zealand Ltd directly.

Please refer to the 'Operation' section of this SOP for information and guidelines about the depth to which the KS100 can be used.

System components

The components are manufactured from steel and are heavy, both as individual components and as assemblies. Particular care should be taken in lifting, assembling and manoeuvring components and assemblies.

KS100

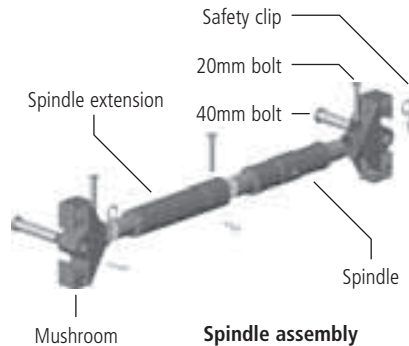
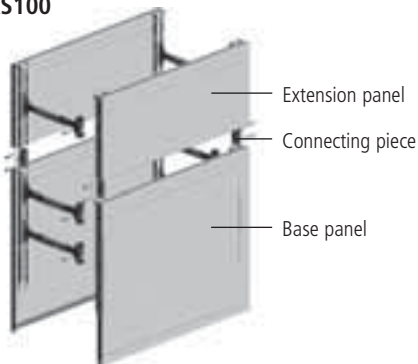

Number of spindle assemblies required: 4 for the base panel, 6 with extension panel.

Notes:

1. Fully assembled a 4m assembly with 1.3m high extensions weighs approximately 3.7 tonnes.
2. A 4m assembly with no extension has an average weight of 2.4 tonnes – this varies slightly depending on the width of the assembly.
3. Generally, a 12 tonne excavator or larger is required to safely lift, manoeuvre and install the KS100 assembly. We recommend a 20 tonne excavator to ensure the most effective and efficient operation.

Checklist

(Checklist to be completed by operators before starting task)

- Am I trained for this task?
- Am I wearing the correct personal protective clothing for this task?
- Do I have the correct personal protective equipment for this task?
- Do I require assistance from a licensed forklift driver or suitably trained crane operator?
- Do I have the correct tools for the task?
- What are the safety devices used on this site for this task? e.g. chains etc.
- Is my work area clear of debris and tools?

Equipment

A 4 point lifting chain, 2.5m minimum leg length, is required to safely unload, assemble and operate the system. If wide assemblies are being used, longer chains are required, up to approximately 3.5m for assemblies 3.0m to 3.3m wide.

The lifting chain must be appropriately rated to lift and handle assemblies weighing up to 3.7 tonnes.

Personal protective equipment (PPE) required:

Safety boots, gloves, hard hat, gloves.

Tools recommended:

4 point lifting chains with locking hooks – rated & certified, Podger bar to turn spindle assemblies, heavy hammer, large shackles.

Component list

- KS100 2.5 x 2.2 base panels
- KS100 2.5 x 1.3 base panels
- KS100 4.0 x 2.2 base panels
- KS100 4.0 x 1.3 base panels
- Spindles
- Mushrooms
- D40 bolts
- D20 bolts
- Safety clips
- 500mm spindle extensions
- 1000mm spindle extensions
- Connecting pieces

Shoring modules (length x height)	Trench width*	Assembly weights (kg)
Base units 4.0m x 2.2m	1.0m - 1.3m	2419
	1.5m - 1.8m	2500
	2.0m - 2.3m	2582
	2.5m - 2.8m	2626
	3.0m - 3.3m	2670
Extension units 4.0m x 1.3m	1.0m - 1.3m	1285
	1.5m - 1.8m	1325
	2.0m - 2.3m	1366
	2.5m - 2.8m	1388
	3.0m - 3.3m	1410
Base units 2.5m x 2.2m	1.0m - 1.3m	1663
	1.5m - 1.8m	1744
	2.0m - 2.3m	1826
	2.5m - 2.8m	1870
	3.0m - 3.3m	1914
Extension units 2.5m x 1.3m	1.0m - 1.3m	1045
	1.5m - 1.8m	1085
	2.0m - 2.3m	1126
	2.5m - 2.8m	1148
	3.0m - 3.3m	1170

* **Note:** Trench width refers to the working width between the inside faces of the panels. Panels are 105mm thick – add 210mm to obtain overall width.

Unloading



The KS100 shoring system will arrive at your site in component form. A packing list will be provided with all components listed together with their weights.

Panels, either 4m long or 2.5m long will arrive flat on the truck deck. Each panel should be lifted off separately by Hiab, or suitable machinery. Place panels well clear of any site operations and within the confines of the work site.



Other components will arrive on a pallet, or in a bin and should be lifted off the truck as a complete pack.

Wherever possible unload and place the components on flat ground.

Care should be taken in all unloading to keep people clear and to ensure no-one is beneath the items during the lifting process.

Hazards:

Heavy components – keep clear and do not place your self underneath while lifting is in progress.

Assembly

Place panel 1 flat on the ground with the attachment points facing upwards.



Place 4 mushrooms in their allocated places and secure with 40mm pins and locking clips.

Lift the 4 spindle assemblies and place vertically into the mushrooms. Secure with 20mm pins and locking clips.

Place panel 2 flat on the ground with the attachment points facing upwards, and secure the other 4 mushrooms into place with 40mm pins and locking clips.

Attach lifting chains each end of panel 2 (2 point lifting) and stand up on its edge. Lower the panel so the mushroom assemblies are facing down.



Once the panel is flat on the ground attach a 4 point lifting chain. Lift panel 2 into place above panel 1. Position carefully so that the mushrooms align with the spindle assemblies. Carefully and slowly lower into place. Secure panel 2 with the 20mm locking pins and clips. Alternatively, fix the mushrooms to the top of the spindle assembly and guide the top panel into position before locking into place with pins and clips.

Hazards:

1. Heavy components – keep clear and do not place yourself underneath while lifting is in progress.
2. Avoid getting hands or fingers in between components, especially when lowering the second panel into place.
3. Take care when lifting spindle assembly components as these are heavy – use sound lifting techniques to avoid damage to backs and keeps hands and fingers clear.

Extension units and spindle extensions

Spindle extensions are either 500mm long or 1000mm long. These are added to the spindle assembly by joining with 20mm pins and safety clips. Generally, they can be added to the assembly while the first panel lies flat on the ground, although, as the width of the assembly grows, some of the spindles and spindle extensions need to be attached first to the second panel which must be carefully lowered until the assemblies can be joined at a height reachable from a standing position.

Positioning of the spindles and spindle extensions is important. These items should be positioned as shown on the photograph. Spindles must always be adjacent to a panel and should be alternated from one side to the other.

When using extension panels, only one spindle assembly is required at each end in the upper position. The bottom of each panel is secured to the top of the base panel by connecting pieces which are pinned and safety clipped.



1.3m extension panel

Note: Only one spindle assembly is required at each end in the upper position

Spindle

Spindle extension

2.2m base panel

Note: Spindles must always be adjacent to a panel and should be alternated from one side to the other

Operation

General



The KS100 is supplied in base units which are 2.2m deep and extension units which are 1.3m deep. When connected the total shored depth is 3.5m.

For almost all situations this should be considered to be the maximum safe operating depth.

However, in some special circumstances, the shoring may be able to be extended deeper by adding a further extension, giving a total shored depth of up to 4.8m.

Please note:

- professional advice must be taken before using at depths greater than 3.5m
- your distributor and/or TSNZ must be advised of the intent to use to an extended depth before any such deployment.

Any damage to the KS100, which occurs as a result of handling, transporting or using the KS100 in ways which are not in accordance with these and any other guidelines or instructions, is strictly the responsibility of the user. Where the equipment is hired, the costs of any damage must be paid to the hirer.

Once assembled, connect the lifting hooks into the lifting eyes on the top edges of the panels and lift the assembly into position adjacent to the trench.



Adjust the spindles to the desired trench width with the Podger bar. Take care to ensure that the two lower spindles are adjusted slightly wider than the top two. One turn of the spindle or approximately 40mm is the correct amount. This will ensure correct alignment of the assembly as it is dug into the trench.

Begin excavation, removing approximately 200mm to 300mm of material. Place the assembly in the trench and begin excavation inside the panels. As excavated material is removed, use the excavator bucket to carefully thrust the panels into the trench. Apply force alternately to each panel and to each end of each panel to avoid straining or breaking the spindle assemblies. The spindle assemblies have a maximum of 8 degrees vertical movement available. As a guide, this is 140mm vertical offset of one panel to the other at 1m width and 460mm vertical offset at the maximum operating width of 3.3m. Continue this process until the trench has reached the desired depth.

No personnel should enter the trench until the shoring system is fully installed to the depth required (a shored assembly depth is up to 3.5 metres including extension panels).

Hazards:

Heavy components – keep clear and do not place yourself underneath the assembly while lifting is in progress.

Operation – continued



Generally at least two shoring assemblies will be required to safely excavate and shore a trench.

Assemble and install the second assembly as for the first.

While the shoring is in place utilise the safely protected work space to lay pipe or undertake other works.

Once work is completed, withdraw personnel from the trench and commence backfilling inside the first assembly. As the backfill depth increases, begin to withdraw the assembly using 4 point lifting chains. Gently alternate the lifting force from one side to the other not exceeding the 8 degree limitation on horizontal movement of the spindle assemblies.

As the shoring assembly is withdrawn continue to backfill until a safe depth is reached, then withdraw the assembly completely.

Leap-frog the assembly to the next position in the line and restart procedures from Operation – Part 1.

Hazards:

Avoid knocking your head on spindle assemblies while working in the trench.

Disassembly



Once the assembly has been lifted clear of the work area, place it on its side on flat ground.

Attach the 4 point lifting chains to the lifting points located on each corner of panel 2.

Take the weight of panel 2 (the top panel) and carefully remove the locking clips and pins which secure the panel and mushrooms to the 4 spindle ends.

Place panel 2 flat on the ground. Detach 4 point lifting chains. Re-attach at each end of panel 2 (2 point lifting chains) and stand up on its edge. Flip and lower the panel so the mushroom assemblies are facing upwards. Remove the mushroom assemblies.

Remove the spindles and mushrooms from panel 1 (the lower panel).

Re-pack all small components into the bin or on to the pallet provided. Ensure all components are accounted for against the packing list (see page 5).

Hazards:

1. Heavy components – keep clear and do not place yourself underneath while lifting is in progress.
2. Avoid getting hands or fingers in between components, especially when lowering the second panel into place.

Take care when lifting spindle assembly components as these are heavy – use sound lifting techniques to avoid damage to backs and keeps hands and fingers clear.

Note: Please ensure all components are completely disassembled before they are freighted back to the supplier.

Loading



The KS100 shoring system is supplied in components. A packing list will be provided with all components listed together with their weights.

Panels, either 4m long or 2.5m should be loaded flat on the truck deck. Each panel should be lifted separately by Hiab, or suitable machinery, and secured onto the truck deck.

Other components are to be loaded on the pallet or bin provided and secured onto the truck deck.

Wherever possible load and place the components on flat ground.

Hazards:

Heavy components – keep clear and do not place your self underneath while lifting is in progress. Ensure chain hooks are correctly positioned and locked.

Care should be taken in all loading to keep people clear and to ensure no-one is beneath the items during the lifting process.



Standards

The KS100 shoring system is certified by TBG in Germany, the organisation of reference for the standardisation of the trench shoring for Europe.

The European standards for shoring form the basis for the Australian Standard AS4744.1, excepting that a lower minimum shield rating of 20kPa is allowed in AS4744.1.

The KS100 system has been independently tested in New Zealand and is certified by a Chartered Professional Engineer to the NZ Dept of Labour OSH Approved Code of Practice for EXCAVATION AND SHAFTS FOR FOUNDATIONS. Loads were referenced from AS4744.1

Disclaimer: Buyers and users of the products and services described in this brochure must make their own assessment of the suitability and appropriateness of the products and services for their particular use and the conditions in which they will be used. All queries regarding product and service suitability, purpose or installation should be directed to Trench Shoring New Zealand Limited or TSNZ-approved distributors for service and assistance. © Trench Shoring New Zealand Limited. Printed 10/08.

Notes

Notes

Notes

Trench Shoring New Zealand

A FLETCHER CONCRETE & INFRASTRUCTURE LIMITED
JOINT VENTURE BUSINESS

0800 SHORENZ (0800 746 7369)